

Glass Vacuum Lifter

SGL 4P Inline



DESCRIPTION

- Safe Working Load 320kg
- Dual circuit vacuum system
- Dual head vacuum pump
- Digital vacuum switches
- Lift bar with adjustable lift points
- Manual tilting – horizontal to vertical
- Low vacuum alert

SPECIFICATIONS

Min Glass Size: 350mm (wide) x 1320mm (height)

Lift Capacity: 320kg

Total Rig Weight: 34kg

Rig Size: 1555mm (length) x 305mm (width) x 233mm (depth)

Tilt: 90 degrees manual

Rotate: 1800 degree manual lockable at 90 degrees

Phone: 0411 429 813

Email: hire@glasslifters.com.au

Web: www.glasslifters.com.au

Technical Data

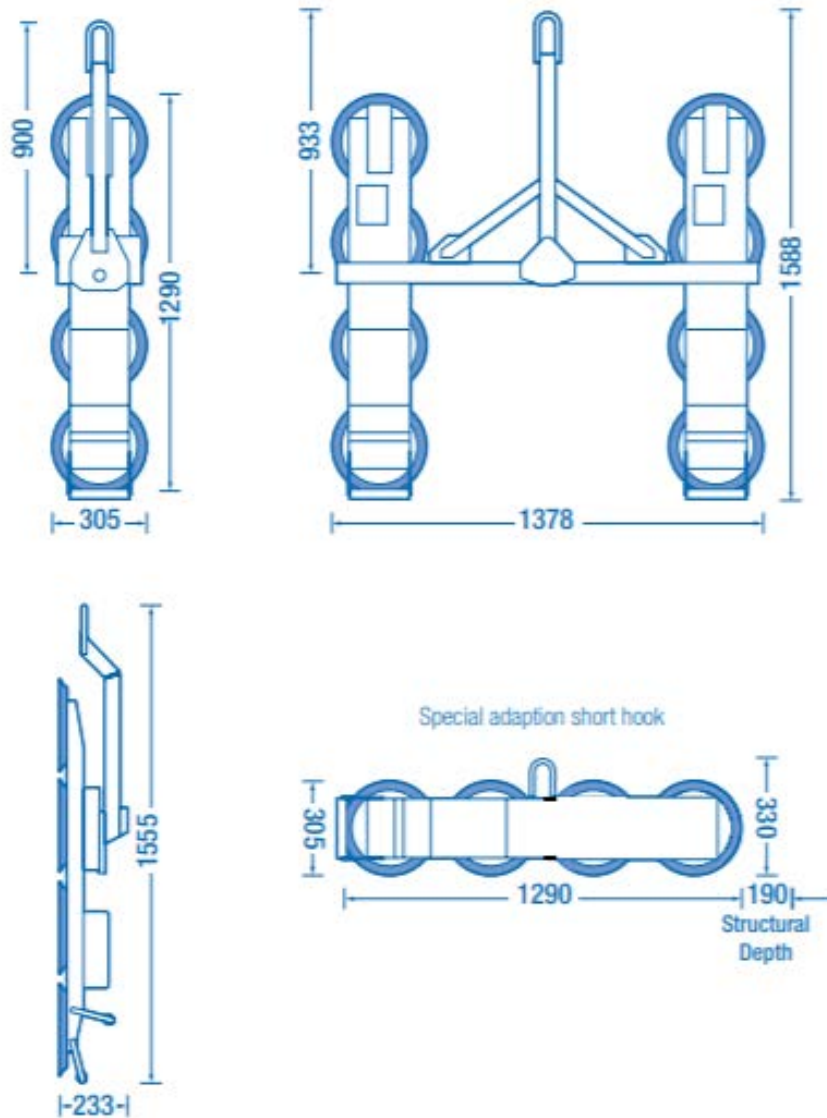

Providing Glass Lifting Solutions for the Construction Industry Since 2006

Phone: 0411 429 813

Email: hire@glasslifters.com.au

Web: www.glasslifters.com.au