

# SYDNEY GLASS LIFTERS

## GLASS LIFTING EQUIPMENT HIRE

P: 0411 429 813 E: HIRE@GLASSLIFTERS.COM.AU W: WWW.GLASSLIFTERS.COM.AU

**SGL - 1500M SWL 1500kg**

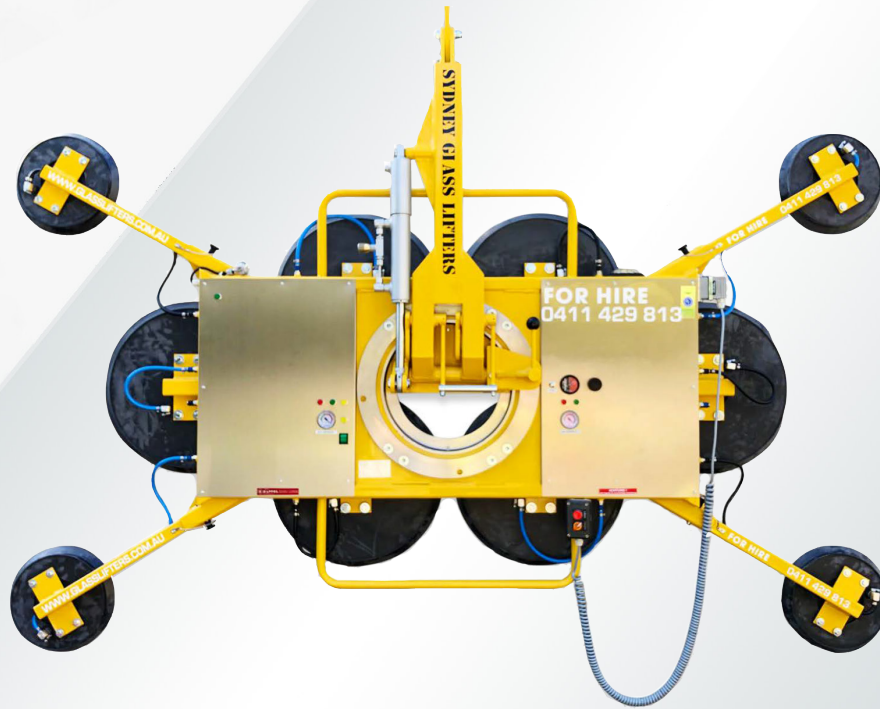

- Safe Working Load 1500kg
- Manual 360 degree lockable rotation, at 90 degrees
- Hydraulically assisted tilting from vertical to horizontal
- Dual, independent vacuum circuits with two vacuum reserve tanks and two non-return valves
- Vacuum gauge for each circuit
- Audio-visual low vacuum alert
- On-board maintenance-free vacuum pump
- Extension arms included as standard

### SPECIFICATIONS

**Min Glass Size:** 2130mm x 1100mm

**Min Glass Width:** Dependent on arm configuration

**Max Glass Size:** Dependent on arm configuration

**Lift Capacit:** 1500kg

**Total Rig Weight:** 250kg

**Rig Size:** HxWxD mm - 1100mm (1850mm with extension) x 1500mm (2300mm with extension) x 220mm

**Tilt:** 90 degrees hydraulically assisted

**Rotate:** 360 degree manual

**SYDNEY GLASS LIFTERS**

15 Short Street, Gladesville, NSW 2111 | Mobile: 0411.429.813 | Fax: 02.9618.2145 | [www.glasslifters.com.au](http://www.glasslifters.com.au) | [hire@glasslifters.com.au](mailto:hire@glasslifters.com.au)

# SYDNEY GLASS LIFTERS

## GLASS LIFTING EQUIPMENT HIRE

P: 0411 429 813 E: HIRE@GLASSLIFTERS.COM.AU W: WWW.GLASSLIFTERS.COM.AU

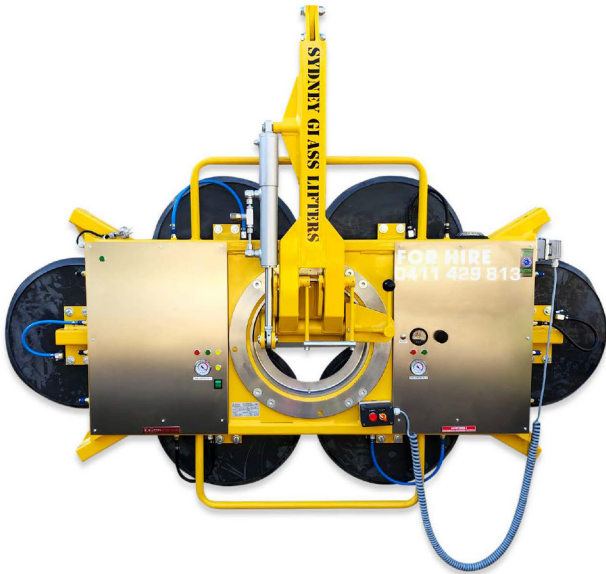
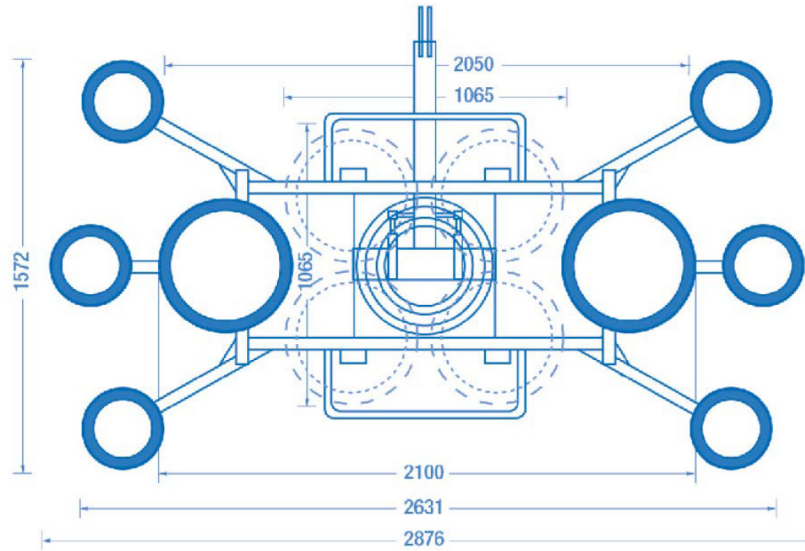

**SYDNEY GLASS LIFTERS**

15 Short Street, Gladesville, NSW 2111 | Mobile: 0411.429.813 | Fax: 02.9618.2145 | [www.glasslifters.com.au](http://www.glasslifters.com.au) | [hire@glasslifters.com.au](mailto:hire@glasslifters.com.au)