

SYDNEY GLASS LIFTERS

GLASS LIFTING EQUIPMENT HIRE

P: 0411 429 813 E: HIRE@GLASSLIFTERS.COM.AU W: WWW.GLASSLIFTERS.COM.AU

GHM 1200



Working Load Limit:	Flat glasses: 800 kg (8 suction pads Ø 400 mm at the device) 1200 kg (12 suction pads Ø 400 mm at the device) Curved glasses: 1000 kg (20 suction pads Ø 280 mm at the device)
Own weight:	ca. 210 kg with suction frame for flat glass panes 8 pcs. suction pad Ø 400 mm ca. 240 kg with suction frame for flat glass panes 12 pcs. suction pad Ø 400 mm ca. 285 kg with suction frame for curved glass panes 20 pcs. suction pad Ø 280 mm
Lifting / Lowering:	by mini crane, counterbalanced truck or telescopic forklift
Movements suction frame:	
Rotate:	360°
Tilt:	0 - 120°
Swivel:	±40°
Suction pads:	8 resp. 12 pcs. Wirth Ø 400 mm / 20 pcs. Wirth Ø 280 mm, other pads on request
Vacuum generation:	Vacuum pump
Energy supply:	Quick exchange battery box, rechargeable battery, 24 V
Operation:	Radio remote control

SYDNEY GLASS LIFTERS

15 Short Street, Gladesville, NSW 2111 | Mobile: 0411.429.813 | Fax: 02.9618.2145 | www.glasslifters.com.au | hire@glasslifters.com.au

SYDNEY GLASS LIFTERS

GLASS LIFTING EQUIPMENT HIRE

P: 0411 429 813 | E: HIRE@GLASSLIFTERS.COM.AU | W: WWW.GLASSLIFTERS.COM.AU

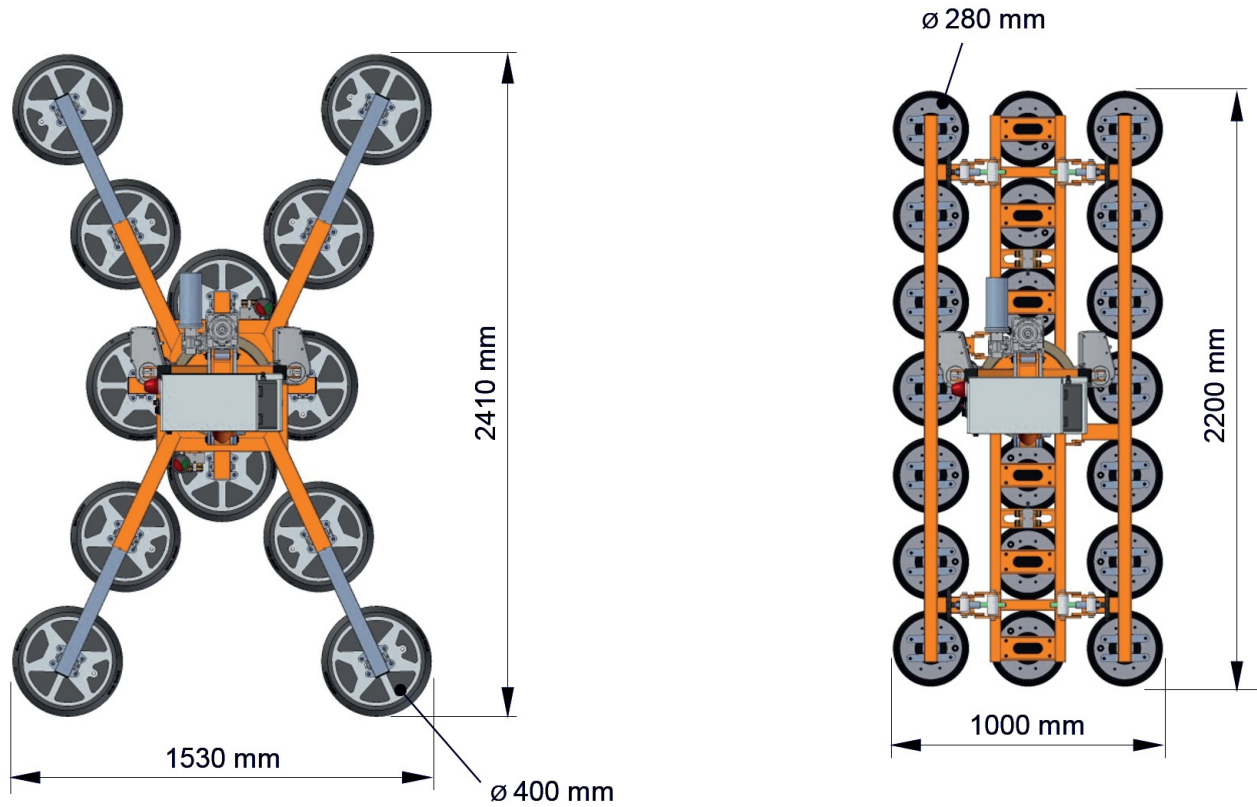

SYDNEY GLASS LIFTERS

15 Short Street, Gladesville, NSW 2111 | Mobile: 0411.429.813 | Fax: 02.9618.2145 | www.glasslifters.com.au | hire@glasslifters.com.au

SYDNEY GLASS LIFTERS

GLASS LIFTING EQUIPMENT HIRE

P: 0411 429 813 E: HIRE@GLASSLIFTERS.COM.AU W: WWW.GLASSLIFTERS.COM.AU

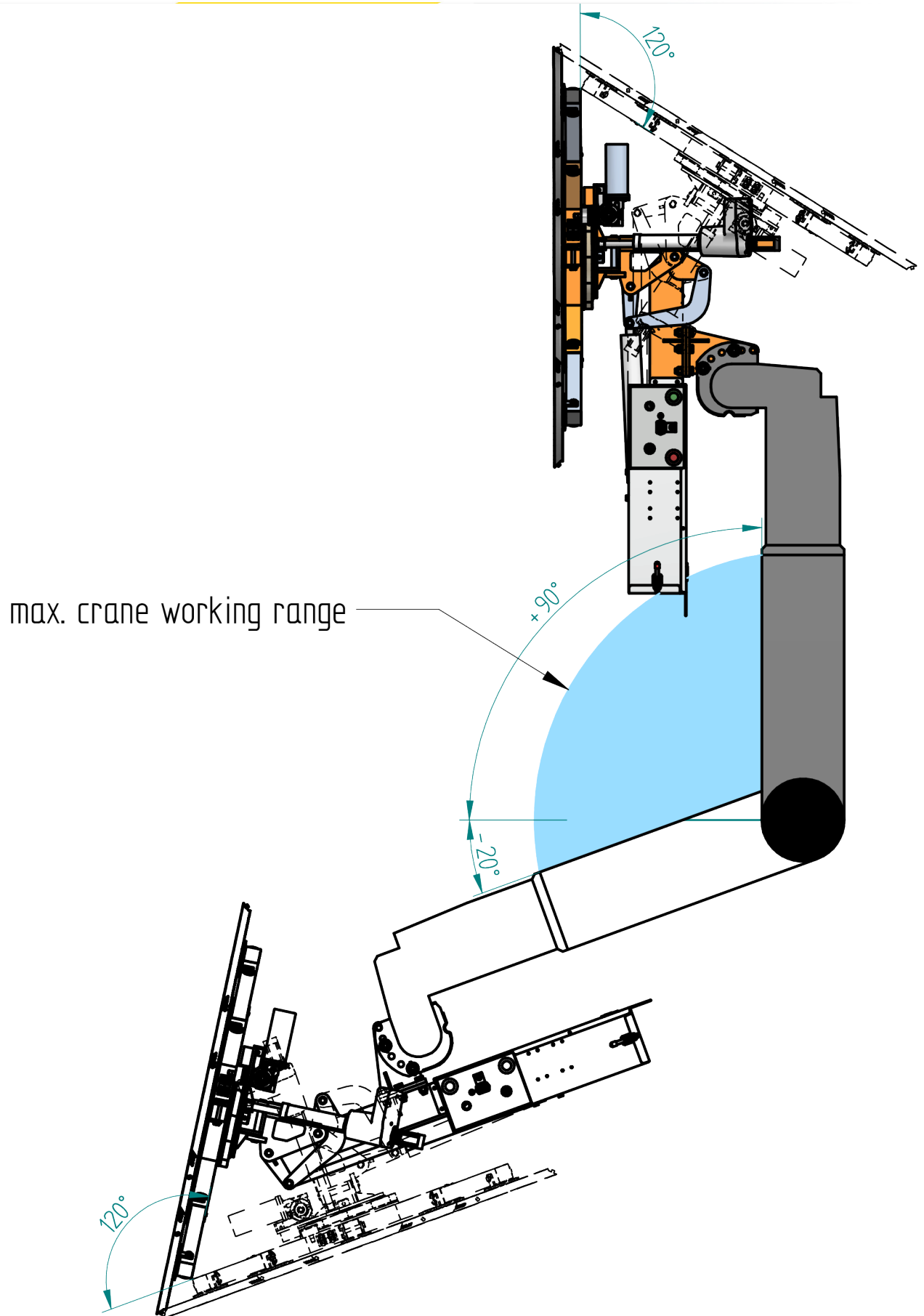

SYDNEY GLASS LIFTERS

15 Short Street, Gladesville, NSW 2111 | Mobile: 0411.429.813 | Fax: 02.9618.2145 | www.glasslifters.com.au | hire@glasslifters.com.au