

Glass Vacuum Lifter

SGL 4P Spider



DESCRIPTION

- Safe Working Load 320kg
- Dual circuit vacuum system with reserve tank, non-return valve and vacuum gauge for each circuit
- 90 degree manual tilting from vertical to horizontal
- Manual 360 degree rotation, lockable at 90 degrees
- Audio-visual low vacuum warning
- Four extension arms to allow alternative configurations
- On-board control panel
- Optional accessories – variable length lifting arm, extra length extension arm, curved or stone pads (270kg capacity), woods pad mount extensions.

SPECIFICATIONS

- Min Glass Size:** Dependent on arm configuration
Min Glass Width: Dependent on arm configuration
Max Glass Size: Dependent on arm configuration
Lift Capacity: 320kg
Total Rig Weight: 54kg
Rig Size: 712mm x 1290mm x 840mm
Tilt: 90 degrees manual
Rotate: 360 degree manual continuous lockable at 90 degrees

Phone: 0411 429 813

Email: hire@glasslifters.com.au

Web: www.glasslifters.com.au

Technical Data

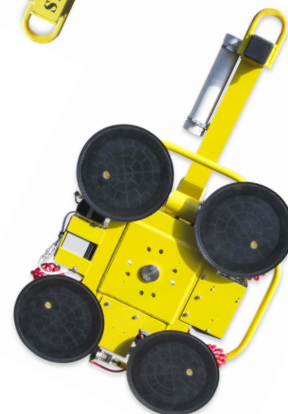
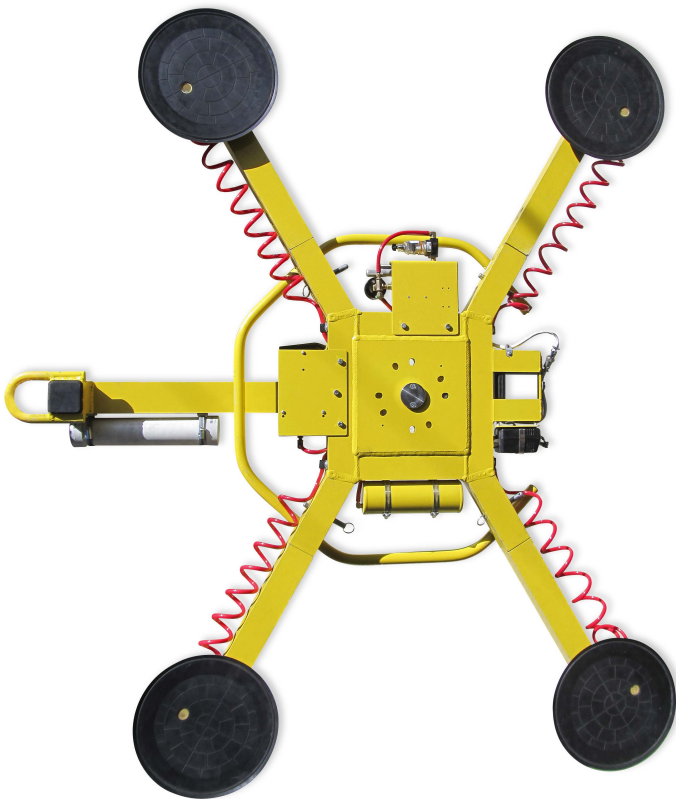
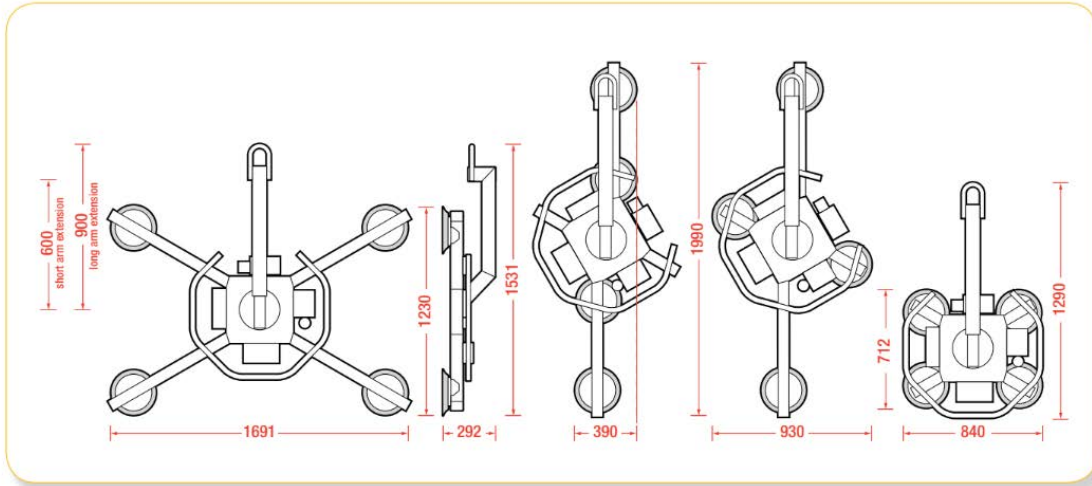

Providing Glass Lifting Solutions for the Construction Industry Since 2006

Phone: 0411 429 813

Email: hire@glasslifters.com.au

Web: www.glasslifters.com.au