

Maeda Mini Crawler Cranes

Little cranes with **BIG** ideas



For further details please contact Sydney Glass Lifters. Due to improvements, the specifications are subject to change without notice.

SYDNEY GLASS LIFTERS
GLASS LIFTING EQUIPMENT HIRE

P: 0411 429 813 E: HIRE@GLASSLIFTERS.COM.AU W: WWW.GLASSLIFTERS.COM.AU



Overall Size

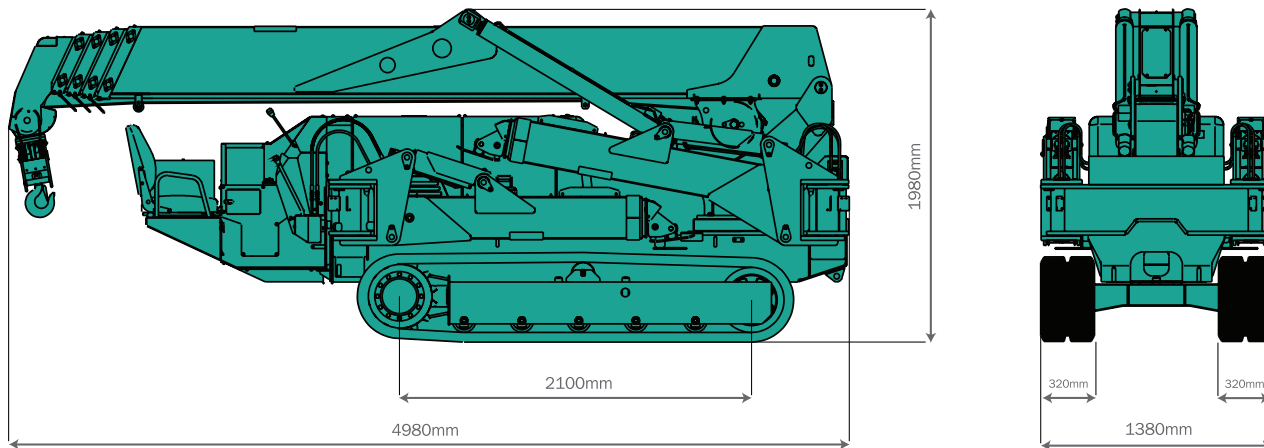

Outrigger Spread Dimensions

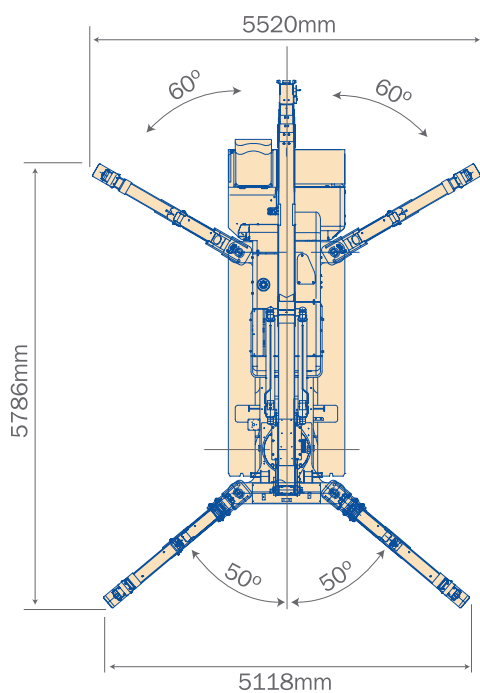

Working Range Chart

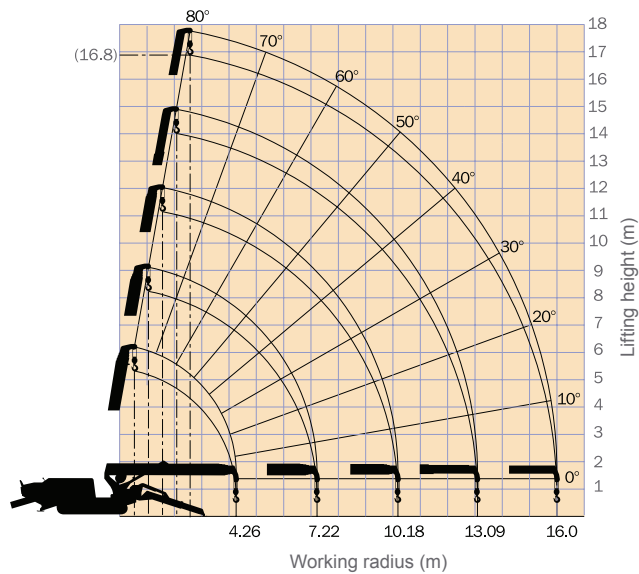

The Working Range Chart does not take into account boom deflection under load.

The maximum reach below ground level is:

Four Fall	Two Fall	Single Fall
20.50m	41.00m	82.00m

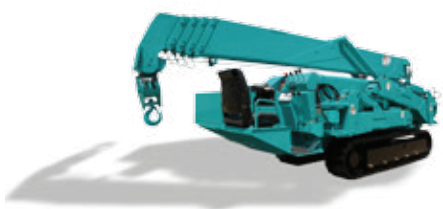

Total rated load (4 falls) Outriggers at Maximum position

4.735m/7.695m boom		10.655m boom		13.565m boom		16.475m boom	
Working radius (m)	Total rated load (kg)	Working radius (m)	Total rated load (kg)	Working radius (m)	Total rated load (kg)	Working radius (m)	Total rated load (kg)
< 2.7	3830	3.5	3030	4.0	2230	5.0	1130
3.5	3030	4.0	2580	4.5	1930	5.5	980
4.0	2580	5.0	2030	5.0	1730	6.0	910
5.0	2030	6.0	1680	6.0	1400	7.0	760
6.0	1680	7.0	1380	7.0	1180	8.0	650
7.0	1380	8.0	1130	8.0	1030	9.0	600
7.25	1330	9.0	880	9.0	930	10.0	550
		10.2	580	10.0	830	11.0	490
				11.0	690	12.0	440
				12.0	530	13.0	380
				13.1	430	14.0	320
						15.0	260
						16.0	210

Total rated load (4 falls) Outriggers at Intermediate position

4.735m/7.695m boom		10.655m boom		13.565m boom		16.475m boom	
Working radius (m)	Total rated load (kg)	Working radius (m)	Total rated load (kg)	Working radius (m)	Total rated load (kg)	Working radius (m)	Total rated load (kg)
< 2.7	3830	3.5	3030	4.0	2230	5.0	1130
3.5	3030	4.0	2580	4.5	1830	5.5	980
4.0	2580	5.0	1880	5.0	1630	6.0	910
5.0	1880	6.0	1430	6.0	1330	7.0	730
6.0	1430	7.0	1130	7.0	1080	8.0	630
7.0	1160	8.0	880	8.0	880	9.0	550
7.25	1120	9.0	740	9.0	730	10.0	480
		10.2	490	10.0	530	11.0	430
				11.0	480	12.0	380
				12.0	430	13.0	330
				13.1	330	14.0	280
						15.0	220
						16.0	180

Total rated load (4 falls) Outriggers at Minimum position

4.735m/7.695m boom		10.655m boom		13.565m boom		16.475m boom	
Working radius (m)	Total rated load (kg)	Working radius (m)	Total rated load (kg)	Working radius (m)	Total rated load (kg)	Working radius (m)	Total rated load (kg)
< 2.7	3830	3.5	3030	4.0	2230	5.0	1130
3.5	3030	4.0	2580	4.5	1830	5.5	980
4.0	2580	5.0	1680	5.0	1630	6.0	880
5.0	1680	6.0	1180	6.0	1180	7.0	730
6.0	1180	7.0	880	7.0	830	8.0	530
7.0	930	8.0	730	8.0	680	9.0	450
7.25	780	9.0	580	9.0	550	10.0	420
		10.2	400	10.0	430	11.0	370
				11.0	380	12.0	330
				12.0	350	13.0	280
				13.1	310	14.0	240
						15.0	190
						16.0	150



The Total Rated Load Charts are based on the actual working radius including boom deflection. The weight of the hook (standard 4 fall - 30kg) must be included as part of the load shown in the Total Rated Load Charts.

When using two fall or single fall hooks, use the appropriate four fall Total Rated Load Chart above but with a **maximum load** of: Two Fall - 1930kg, Single Fall - 970kg.





Maeda MC405CRM

Technical specifications

Offering the best balance of power and design



- Pick & Carry Duty (500kg maximum)
- Two Travel Speeds
- Programmable Moment Limiter
- 1130kg at 5.0m radius on 16.43m boom
- Rubber Tracks
- Hydrostatic Transmission
- Centralised Controls
- 4 Fall / 2 Fall Hook Block
- Automatic Hook Stowage System
- Tilt Sensor/Alarm
- Powerful Winch with Hydraulic Disc Brake
- Two Speed Winch
- Fully Automatic Pentagonal Section Boom
- Cable Remote Controller

Specification		
Model		MC405CRM
Crane capacity		3.83t x 2.7m
Max. working radius		16m
Max. lifting height		16.8m
Hook speed		10m / min. (18.0m / min.) (4 falls, 4th layer)
Single line speed		40m / min. (72.0m / min.) (4th layer)
Hoist rope		IWRC 6 x WS(26) 8mm x 95m
Telescopic system	Boom length Telescoping speed Boom type	4.735m - 16.475m 11.7m / 54.2 sec (41.3sec) Fully automatic 5 section pentagonal telescopic boom
Boom hoist system	Hoist angle / speed	0° - 80° / 24.5 sec (17.0 sec)
Slew system	Slew angle / speed	360° / 2.5 rpm (2.1 rpm)
Outrigger system	Type Maximum extended dimensions	Extension and set up by direct acting hydraulic cylinders (Length) 5786mm x (Front) 5118mm x (Rear) 5520mm
Traction system	Drive Travel speed Gradability Crawler length x width Ground pressure	Hydraulic motor driven, stepless speed changer 0 - 3.3 km/h 20° 2100mm x 320mm 49.0 (0.50) kpa (kgf/cm ²)
Engine	Model Type Rated output Starting method Fuel / Fuel tank capacity	Yanmar 3TNV88-PMB 3 cylinder water cooled diesel 21.8kw/2400min-1 (29.6PS/2400rpm) Electric Diesel/60L
Remote control system	Type	Cable remote controller, micro-speed mode, load display for transmitter, outrigger operation
Dimensions	Length x Width x Height Weight MC405CRM Weight MC405CRME	4980mm x 1380mm x 1980mm 5600kg 5750kg
Standard equipment		Overwind protection, load indicator, hydraulic safety valve, wire rope latch, level, machine body inclination alarm, EMO switch, travel lock lever, outrigger interlock device, moment limiter, rotary lamp, 4-fall / 2-fall hook block.
Optional equipment		Radio remote control, white rubber tracks, single fall hook, searcher hook, fly-jib. Electric motor.