

# SYDNEY GLASS LIFTERS

## GLASS LIFTING EQUIPMENT HIRE

P: 0411 429 813 E: HIRE@GLASSLIFTERS.COM.AU W: WWW.GLASSLIFTERS.COM.AU

**Counter Balance 1000kg**

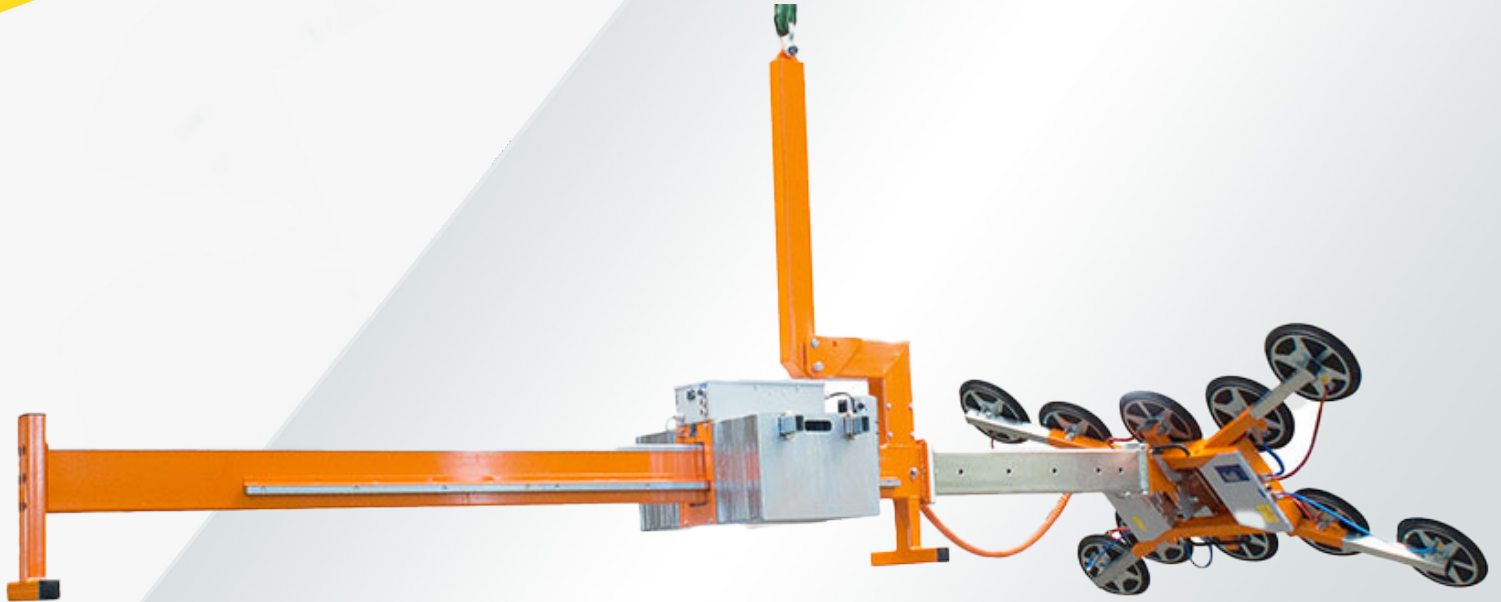

- Max 1000kg load
- Lifting and positioning construction elements and large-sized glass to places with difficult access (e.g below eaves, balconies, stages etc)
- Compatible with a load hook and slings or vacuum lifter
- Electronically driven counter weights operated by cable or remote control for balancing loads up to 1000kgs
- Battery-powered energy supply with high capacity
- Built in gauge for energy monitoring energy supply

Dimensions	1790mm Height x 2750mm length
Overhang Adjustable	255mm Minimum / 1255mm Maximum
Stowed Dimensions	990mm Height x 3010mm Length
Inclination	+/- 10 degrees
Power	Batteries 24v / 12Ah

**SYDNEY GLASS LIFTERS**

15 Short Street, Gladesville, NSW 2111 | Mobile: 0411.429.813 | Fax: 02.9618.2145 | [www.glasslifters.com.au](http://www.glasslifters.com.au) | [hire@glasslifters.com.au](mailto:hire@glasslifters.com.au)



# SYDNEY GLASS LIFTERS

## GLASS LIFTING EQUIPMENT HIRE

P: 0411 429 813 | E: [hire@glasslifters.com.au](mailto:hire@glasslifters.com.au) | W: [www.glasslifters.com.au](http://www.glasslifters.com.au)



**SYDNEY GLASS LIFTERS**

15 Short Street, Gladesville, NSW 2111 | Mobile: 0411.429.813 | Fax: 02.9618.2145 | [www.glasslifters.com.au](http://www.glasslifters.com.au) | [hire@glasslifters.com.au](mailto:hire@glasslifters.com.au)



# SYDNEY GLASS LIFTERS

## GLASS LIFTING EQUIPMENT HIRE

P: 0411 429 813 E: HIRE@GLASSLIFTERS.COM.AU W: WWW.GLASSLIFTERS.COM.AU

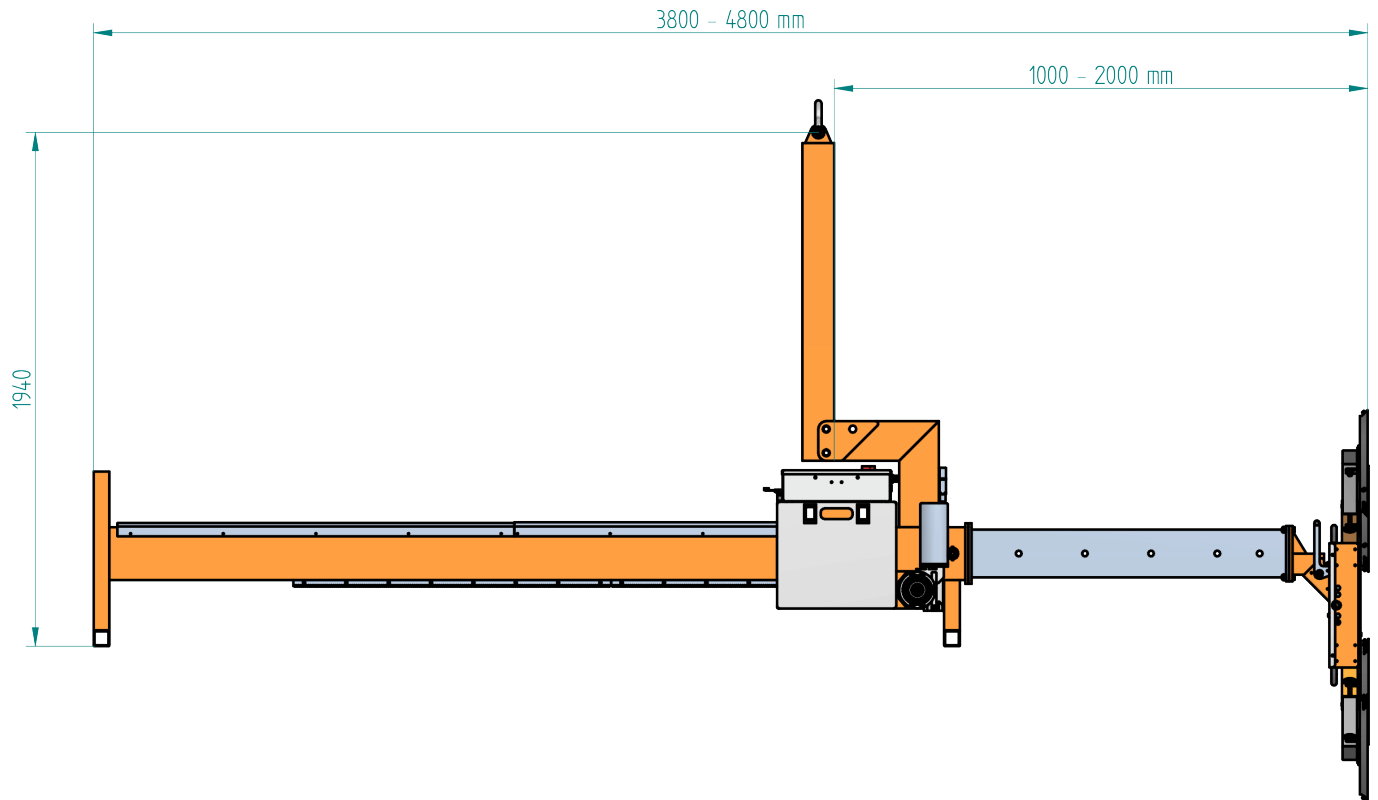

### OKTOPUS® GLASS-Jack GL-KN1000

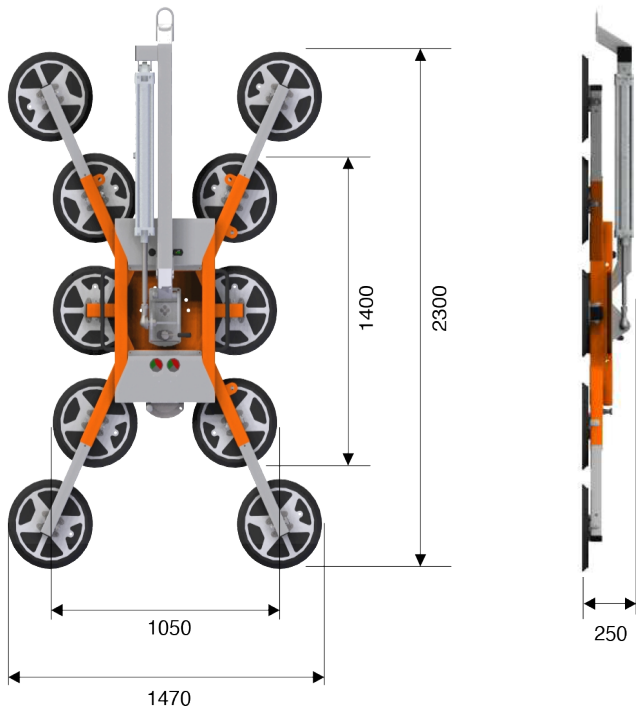

## SYDNEY GLASS LIFTERS