

SYDNEY GLASS LIFTERS

GLASS LIFTING EQUIPMENT HIRE

P: 0411 429 813 E: HIRE@GLASSLIFTERS.COM.AU W: WWW.GLASSLIFTERS.COM.AU

GHM 600



- SLL 300kg (4 pads) // 600kg (8 pads)
- Rotating, swivelling and tilting functions are all remote controlled
- Voltage pump: 24DC, 2 rechargable batteries
- Vacuum gauge for each circuit
- Audio and visual low vacuum alert
- Attachment for mini-crane, extention arms available

Dimensions HxWxD (with extensions)	850mm(1280)x960mm(1880mm)x1280mm
Powered Movement	Head unit: Up and Down 60 degrees, Pad frame: rotation 95 degrees, Head slew: Left and Right 40 degrees
Vacuum System	Dual circuit vacuum with 2 pumps and 2 vacuum tanks
Weight of lifter	170kg
Pad Dimensions	4x400mm // 8x400mm

SYDNEY GLASS LIFTERS

15 Short Street, Gladesville, NSW 2111 | Mobile: 0411.429.813 | Fax: 02.9618.2145 | www.glasslifters.com.au | hire@glasslifters.com.au

SYDNEY GLASS LIFTERS

GLASS LIFTING EQUIPMENT HIRE

P: 0411 429 813 E: HIRE@GLASSLIFTERS.COM.AU W: WWW.GLASSLIFTERS.COM.AU

300kg max capacity 4 pads

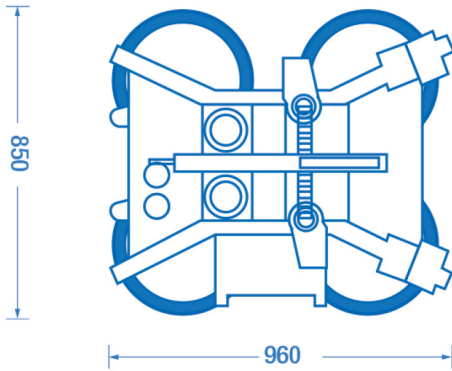

600kg max capacity 8 pads

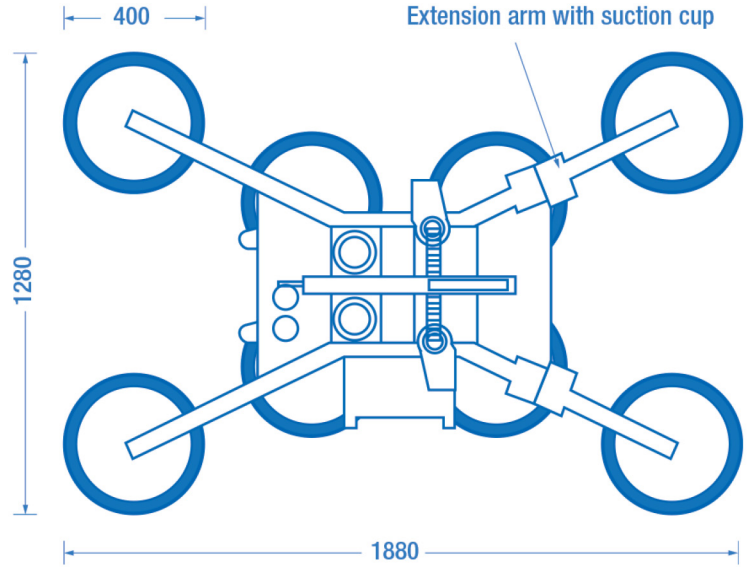

SYDNEY GLASS LIFTERS

15 Short Street, Gladesville, NSW 2111 | Mobile: 0411.429.813 | Fax: 02.9618.2145 | www.glasslifters.com.au | hire@glasslifters.com.au